

# SDV1100-A-BB: LOW PROFILE, CEILING MOUNTING SPEAKER

## FEATURES

- SIMPLE TO INSTALL
- PROVEN DESIGN
- DISCRETE
- USES CUSTOM 4" DRIVER WITH ENHANCED BASS REPRODUCTION
- HIGH QUALITY SOUND REPRODUCTION
- INTEGRAL ACOUSTIC LENS TO OPTIMISE SOUND DISPERSION
- HIGH SENSITIVITY
- TAMPER EVIDENT
- AVAILABLE IN WHITE or BLACK<sup>1</sup>
- EASY CONNECTIONS VIA "PIANO KEY" TERMINATIONS
- ROBUST – BODY ALL METAL CONSTRUCTION.
- SMALL FOOTPRINT
- COMPATIBLE WITH SDV1095-6 AMPLIFIER UNIT
- CAN BE COMBINED DIRECTLY WITH WALL OR OTHER CEILING MOUNTED SPEAKERS IN THE ETS RANGE<sup>2</sup>
- LOW COST
- LIGHTWEIGHT



## DESCRIPTION

The SDV1100-A-BB is a low profile, ceiling mounting speaker. The speaker is designed to blend unobtrusively into mineral fibre (plasterboard) ceilings or ceiling tiles. For metal tile ceilings the SDV1103-A metal tile ceiling speaker should be considered.

Complementary to the SDV1100-A-BB speaker is the SDV1111-A ceiling mounted sub-woofer speaker assembly. The SDV1100-A-BB speaker can be driven by the ETS class D amplifier unit (SDV1095-6-A). The amplifier can drive 2, 4 or 6 combinations of the SDV1100-A-BB speakers as well as a single sub-woofer unit. In addition, the SDV1100-A-BB can be mixed with the Bowman range of wall speakers (SDV1101-A) and ceiling channel speakers (SDV1102-A). For full details about the possible permutations of the ETS speaker range please contact EcoTec Systems Ltd or their authorised representative.

## APPLICATIONS

- RETAIL BACKGROUND MUSIC SYSTEMS
- BACKGROUND MUSIC SYSTEMS FOR LEISURE CLUBS
- BACKGROUND MUSIC SYSTEMS FOR RESTAURANTS AND BARS.
- MUSIC SYSTEMS FOR NIGHT CLUBS
- HOME CINEMA SYSTEMS

### NOTES

- 1) Other colours available to special order.
- 2) See
 

SDV1100-A	Classic ceiling speaker
SDV1101-A	Slimline wall speaker
SDV1102-A	Channel speaker
SDV1111-A	Bass speaker

# SPECIFICATIONS



## Characteristics at a free air temperature of 25°C

PARAMETER	NOTES/TEST CONDITIONS	VALUE			UNIT
		MIN	TYP	MAX	
P	POWER HANDLING			40	W
W	WEIGHT	Excludes packaging			g
Ø, H	DIMENSIONS	Diameter and height			mm
R	IMPEDANCE	Measured at 1KHz			Ω
Fr	FREQUENCY RESPONSE	Driven with EcoTec Systems Ltd class D amp, mounted in plasterboard ceiling.			Hz
SD	SENSITIVITY	Measured at 1m from speaker			dB

### Ceiling Cut-out Dimensions

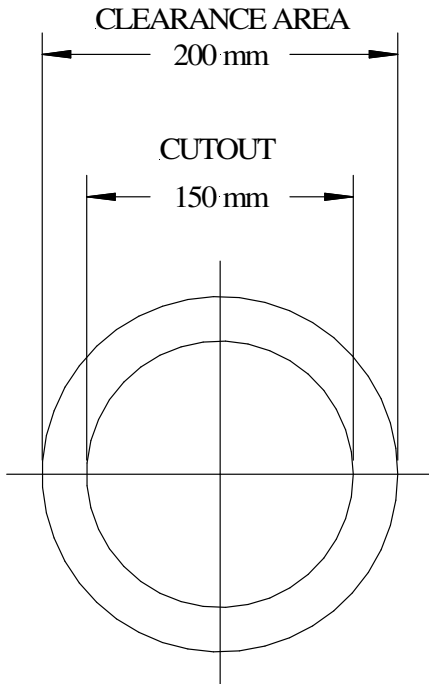

### Installation Notes

1. Cut out suitable size hole in ceiling as shown opposite.
2. Remove grille from speaker using a 2mm Allen key (retain screw for refitting later).
3. With the grille removed, the 4 adjusting screws which control the mounting arms are visible.
4. Push the mounting tabs towards until they rest on the back box.
5. Connect up speaker wires (brown is in-phase +ve, blue is out of phase -ve)
6. Fit speaker into cut-out in the ceiling.
7. Rotate the adjuster screws using a 3mm Allen key to secure the speaker into the ceiling.
8. Re-fit the grille using the screw removed in (2) above.
9. Clean surface of grille and fit EcoTec Systems Ltd logo sticker over screw head in grille.

EcoTec Systems Ltd. reserve the right to change the products shown on this datasheet in the interest of improved specification. No responsibility is assumed for the use of information contained herein, nor for any infringement of patent or rights of others that may result from such use. No license is granted by implication or otherwise under any patent or patent right of EcoTec Systems Ltd.